



MONTIGO[®]
the art of fireplaces
www.montigo.com

H-Series
Direct Vent
Flush Face
See-Thru Fireplace



H38DF-ST shown

H-Series

Direct Vent, Flush Face See-Thru Fireplace



Unit Dimensions												
	A	B	C	D	E	F	G	H	I	J	K	L
H38DF-ST	37 3/4"	36 1/2"	35 1/4"	1 1/4"	25"	1"	24"	35 3/4"	7 1/4"	5"	8"	33 1/2"
H42DF-ST	42"	40 1/2"	39 1/2"	1 1/4"	28 3/4"	1"	24"	40"	7 1/4"	5"	8"	37 1/2"

Features:

- ❑ Convertible using Top or Rear Direct Vent‡
- ❑ Flush or Clean-Face Design allows for brick or tile installation over the fireplace frame
- ❑ Unique pan burner design and technology
- ❑ Large viewing areas for a full view of the spectacular fire
- ❑ Snap-Lock door system
- ❑ Hi/Lo control for adjusting flame level
- ❑ Piezo spark ignition
- ❑ Millivolt control allows for continuous operation, even during a power failure
- ❑ 100% fail-safe shut-off valve on all models

Options:

- ❑ Factory installed electronic ignition with available battery backup
- ❑ Wireless remote control
- ❑ Traditional style Logset
- ❑ Contemporary with glass beads†
- ❑ Full stainless steel construction for outdoor use

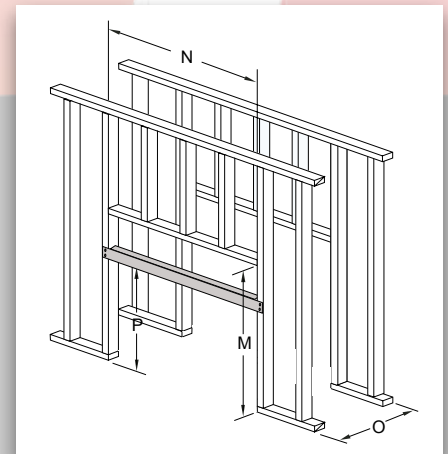
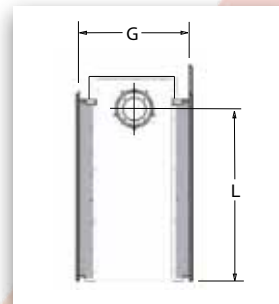
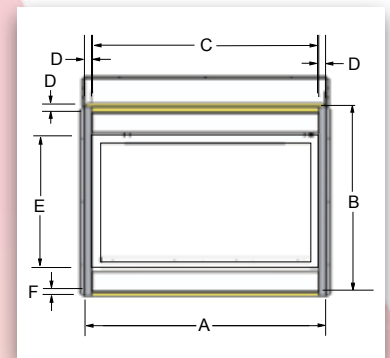
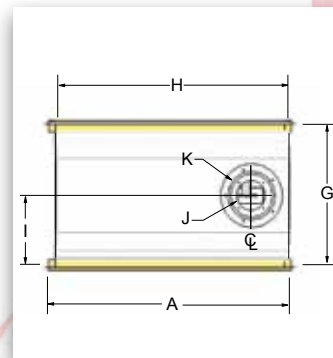

Fireplace BTU/H Input			
Model#	Natural Gas	Liquid Propane	Glass Size [L x H]
H38DF-ST	34,000	32,000	35 1/4" X 25"
HL38DF-ST	34,000	32,000	35 1/4" X 25"
H42DF-ST	37,000	37,000	39 1/2" X 28 3/4"
HL42DF-ST	37,000	32,000	39 1/2" X 28 3/4"

Framing Dimensions				
	M	N	O	P
H(L)38DF-ST	42"	40 3/4"	23 3/4"	N/A
H(L)42DF-ST	49"	45"	23 3/4"	46 1/2"

‡ H(L)38ST Only

† Visit our Website @ www.montigo.com for samples

Consult the owner's manual for complete installation instructions and proper clearances to combustible surfaces prior to installing fireplace.

All specifications, framing dimensions, product designs, materials and colors are subject to change without notice. The actual flame pattern and color may vary slightly from the illustrations. Diagrams and illustrations are not to scale.

Warranty: The manufacturer warrants this fireplace to be free from defects in materials and workmanship at the time of manufacture. There is a limited 10 year warranty on the firebox; 5 year limited warranty on the burner and 1 year limited warranty on the pilot burner assembly and fan motors (if included). The valve carries a limited 1 year warranty unless otherwise specified in the installation manual. Glass, plated/painted finishes and refractory lining are exempt.



www.montigo.com

Ferndale, Washington
TF 1.800.789.6236
FX 1.866.300.0927

Langley, British Columbia
TF 1.800.378.3115
FX 1.604.607.6462



Available at:

Printed in Canada

P/N XB2008

030711